

VSF110D-S SERIES

Ventilation Fan with DC Motor



Description:

Slim Fit ventilating fan shall be ultra-quiet, ceiling or wall mount engineered for continuous operation. DC Motor with adjustable speed control. Suitable for new construction or remodeling. ENERGY STAR qualified and certified by the Home Ventilating Institute (HVI). ETL/cETL listed for use in insulated ceilings.

Motor/Blower:

- Permanently lubricated high performance DC motor.
- Engineered for continuous operation.
- Power rating shall be 120v/60Hz.
- Fan shall be UL and cUL listed for tub/shower enclosure when GFCI protected.
- Motor equipped with thermal shut-off.

Housing:

- 26 GA Galvanized Steel Body
- Detachable 4" & 6" Duct connector
- Built-in damper
- 2—24" expandable anti-vibration brackets included.
- Designed for installation in ceilings with a minimum of 6" clearance.

Grille:

Contemporary design, wipes clean. Attaches to housing with torsion springs. Round on square design.

Finishes: White (W).

Ventilating Area:

For bathrooms up to 150 square feet.

Warranty:

6 Years when installed by licensed professional.

Architectural Specifications:

Ventilation fan will be ceiling or wall mount, ENERGY STAR qualified, with no less than 110CFM and no more than 0.6 Sones as certified by HVI at 0.1 static pressure in inches water gauge. Power consumption shall be no greater than 11 watts and ENERGY STAR rated with an efficiency rating of no less than 10CFM/watt. The motor will be an enclosed, brushless DC motor, engineered for continuous operation. Duct diameter will be 4" or 6" round. CFM switch will allow for 3 separate airflow settings. Fan shall be listed for tub/shower enclosure when used with GFCI branch circuit wiring and shall be ETL/cETL listed for use in insulated ceilings (Type I.C.). Fan shall be ASHRAE 62.2, LEED, California Title 24 and Washington VIAQ compliant.

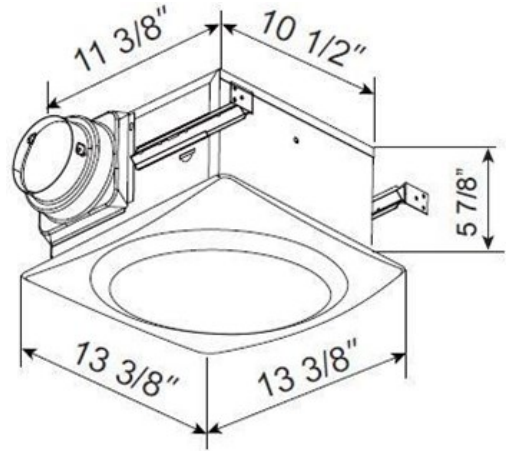

W

Model: VSF110D Series	6" Duct	
Static Pressure (inches w.g.)	0.1	0.25
Air Volume (CFM)	110	79
Noise (Sones)	0.6	n/a
Power Consumption (Watts)	11	11
Energy Efficiency (CFM/Watts)	10	7.2
Current (Amps)	0.2	0.2
ENERGY STAR rated	YES	
Grille Dimensions	13 3/8" x 13 3/8"	



Model	Qty	Comments	Project
			Location
			Architect
			Engineer
			Contractor
			Submitted by:
			Date: