

# CP70-S SERIES

## Ultra Slim Fit Ventilation Fan



### Description:

Ultra Slim Fit, AC Bathroom Fan . Ceiling or Wall Mount. Fits 2x4 construction. HVI Certified. Suitable for new construction or remodeling. ETL/cETL listed for use in insulated ceilings (Type I.C.).

### Motor/Blower:

- Permanently lubricated AC Motor
- Engineered for continuous operation.
- Power rating shall be 120v/60Hz.
- Fan shall be UL and cUL listed for tub/shower enclosure when GFCI protected.
- Motor equipped with thermal shut-off.
- Removable Blower Assembly with Centrifugal Blower Wheel

### Housing:

- Galvanized Steel Body
- 4" duct connector
- Built-in backdraft damper
- Built-in Mounting ears
- Designed for installation in ceilings with a minimum of 4" clearance.

### Grille:

Low maintenance, attaches to housing with torsion springs.

**Finishes:** White (W)

### Ventilating Area:

For bathrooms up to 70 square feet.

### Warranty:

4 Years when installed by licensed professional.

### Architectural Specifications:

Ventilation fan will be ceiling mount or wall mount, with no more than 3.5 Sones at 70CFM as certified by HVI at 0.1 static pressure in inches water gauge. Duct diameter will be 4' round. Fan shall be listed for tub/shower enclosure when used with GFCI branch circuit wiring and shall be ETL/cETL listed for use in insulated ceilings (Type I.C.).

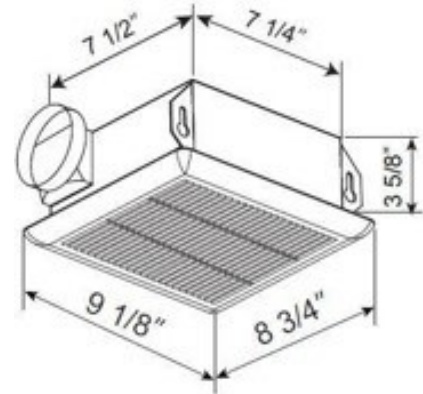

Model: CP70 Series	4" Duct
Static Pressure (inches w.g.)	0.1
Air Volume (CFM)	70
Noise (Sones)	3.5
Power Consumption (Watts)	50
Current (Amps)	1.2
ENERGY STAR rated	NO
Grille Dimensions	9 1/8" x 8 3/4"



Model	Qty	Comments	Project
			Location
			Architect
			Engineer
			Contractor
			Submitted by:
			Date: