

CP100-S SERIES

Slim Fit Energy Star Ventilation Fan



Description:

Slim Fit, AC Bathroom Fan. Ceiling or wall mount. Suitable for new construction or remodeling. Fan shall be ENERGY STAR qualified and certified by the Home Ventilating Institute (HVI). ETL/cETL listed for use in insulated ceilings (Typel.C.).

Motor/Blower:

- Permanently lubricated AC Motor
- Engineered for continuous operation.
- Power rating shall be 120v/60Hz.
- Fan shall be UL and cUL listed for tub/shower enclosure when GFCI protected.
- Motor equipped with thermal shut-off.
- Removal centrifugal type blower wheel assembly.

Housing:

- Galvanized Steel Body
- 4"round detachable duct connecter
- Built-in backdraft damper
- Articulating and expandable anti-vibration brackets included.
- Designed for installation in ceilings with a minimum of 6" clearance.
- May be mounted in sloped ceilings up to 45 degree pitch

Grille:

Low maintenance, attaches to housing with torsion springs.

Finishes: White (W)

Ventilating Area:

For bathrooms up to 100 square feet.

Warranty:

4 Years when installed by licensed professional.

Architectural Specifications:

Ventilation fan will be ceiling mount, ENERGY STAR qualified, with no less than 100CFM and no more than 2.0 Sones as certified by HVI at 0.1 static pressure in inches water gauge. Power consumption shall be no greater than 27 watts and ENERGY STAR rated with an efficiency rating of no less than 2.7CFM/watt. The motor will be permanently lubricated and engineered for continuous operation. Duct diameter will be a 4" round detachable duct. Fan shall be listed for tub/shower enclosure when used with GFCI branch circuit wiring and shall be ETL/cETL listed for use in insulated ceilings (Type I.C.).

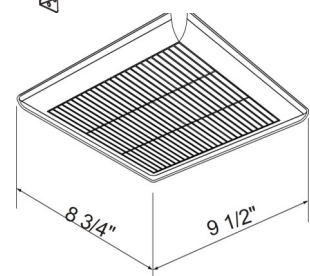
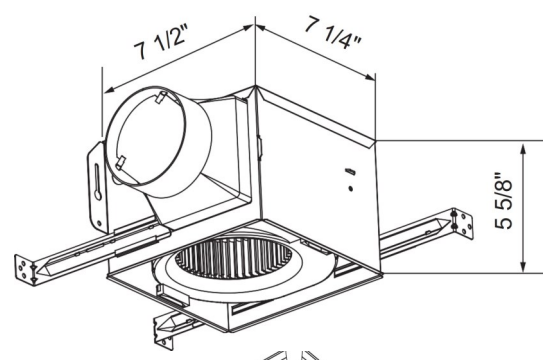

Model: CP100 Series	4" Duct
Static Pressure (inches w.g.)	0.1
Air Volume (CFM)	100
Noise (Sones)	2.0
Power Consumption (Watts)	27
Current (Amps)	1.2
ENERGY STAR rated	YES
Grille Dimensions	8 3/4" x 9 1/2"



Model	Qty	Comments	Project
			Location
			Architect
			Engineer
			Contractor
			Submitted by:
			Date: